



# MANUAL DE INSTALACION

## Soportes Estribos Blacktrend SEA160

Fiat Toro Cabina Doble. Modelo 2016->

### 1 CONTENIDO

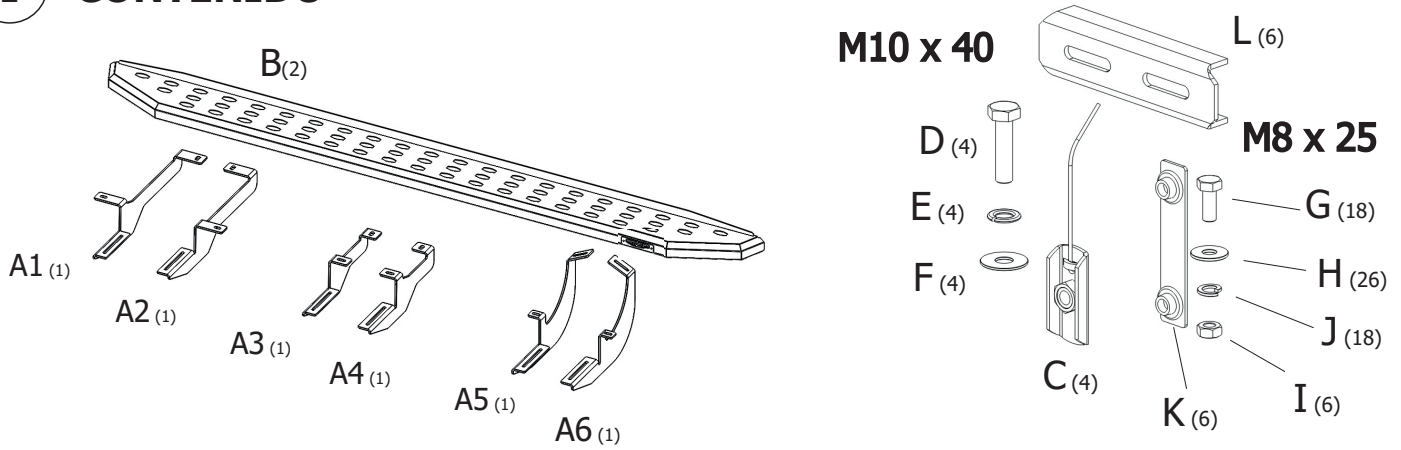

### 2 HERRAMIENTAS NECESARIAS

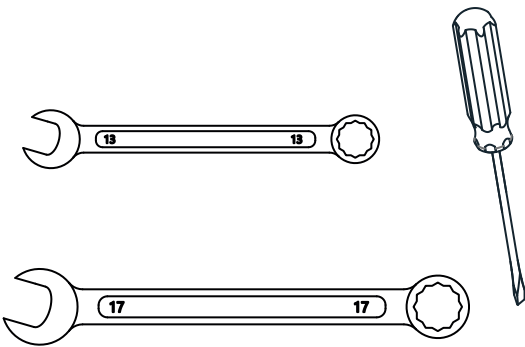

### 3 SUJECIÓN DEL ESTRIBO

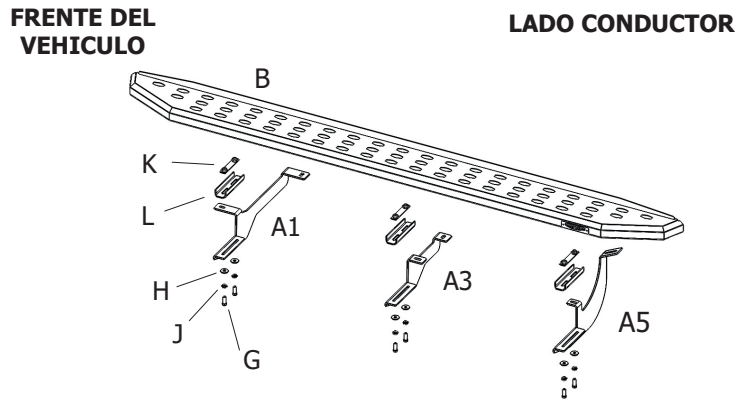

### 4 ARMADO DEL SOPORTE CON EL ESTRIBO

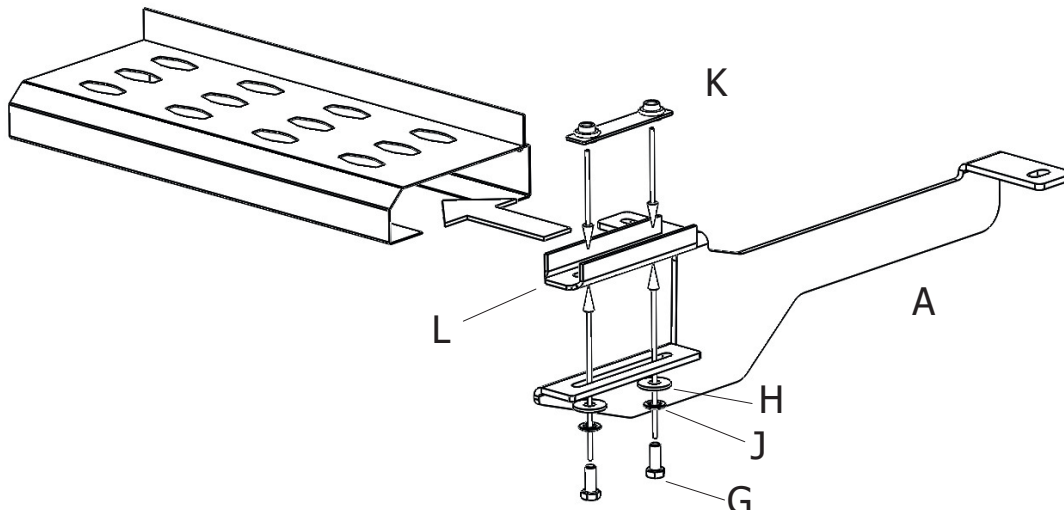

#### Valores de apriete de tornillos

Unidades	M4	M6	M8	M10	M12	M14
Kg.m	0,3	1	2,5	5,1	8,7	14
Coeficiente de fricción: $\mu=0,14$						